

# Re-usable grease collecting cartridge

Makes maintenance faster, cleaner and more cost-effective

The re-usable grease collecting cartridge gives maintenance staff an easy way to remove waste grease from a bearing. It is installed by screwing it into an adapter that fits directly onto the bearing. One distinct advantage is that the cartridge fills to its full capacity. Incoming grease moves a follower piston. This piston stops when the flow of waste grease stops – and when the cartridge is full. This avoids overfilling and grease leakage. The cartridge is then removed, and the grease ejected by pressing the piston. Removing the cartridge – and remounting it for re-use – are also simple.

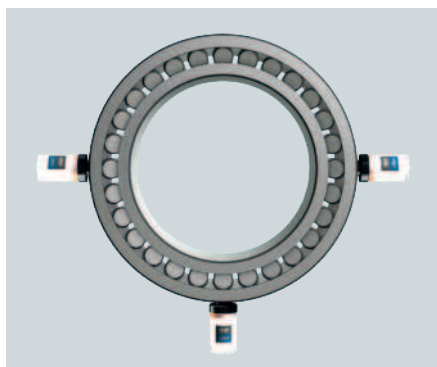

Removing old grease from a bearing has become a delicate environmental operation. Typically, used grease is sucked from the bearing into a cartridge, bottle or bag. However, many of these containers cannot use their full volume – so quickly fill up and become blocked.

Changing the container more frequently is the answer, but this is cost- and resource-intensive. In addition, the container and grease have historically been disposed of together – but this is something that responsible engineering companies are now keen to avoid.



The new re-usable grease collecting cartridge overcomes both these problems. It collects larger volumes of grease because it can be filled to maximum capacity.

In addition, the grease can be ejected easily from the cartridge, and recycled appropriately. The cartridge itself is then cleaned and re-used multiple times – another environmental benefit.

## Benefits:

- Using the complete cartridge volume helps to prolong service intervals.
- Cartridge is easy to empty using simple tools – such as a screwdriver – which helps to cut maintenance time
- Grease can be emptied from cartridge and disposed of – allowing the cartridge to be re-used many times
- System helps companies meet environmental targets, as grease and cartridge are not disposed of together
- Target markets include wind energy and other large bearing applications such as ship engines and rolling mills

A standard cartridge is 900 ml, but larger and smaller sizes are available on request.

The system works by screwing an adapter into an outlet of the bearing, then screwing a cartridge into the adapter. The adapter has two different thread sizes (M14 x 1.5 and M16 x 1.5).

This allows it to be used in multiple applications. Target markets include wind energy and other large bearing applications such as ship engines, rolling mills and tidal power plants.

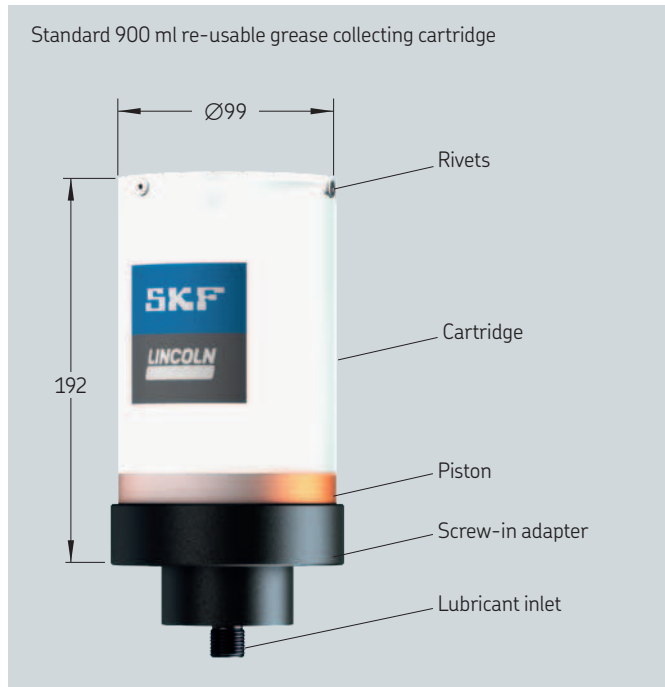

#### Order details

Part number	Description
5320-00000021	Re-usable grease collecting cartridge complete with 400 ml cartridge and M14x1,5 adapter
532-60533-1	Re-usable grease collecting cartridge complete with 900 ml cartridge and M14x1,5 adapter
532-60707-1	Re-usable grease collecting cartridge, complete with 900 ml cartridge and M16x1,5 adapter
5320-00000032	Re-useable grease collecting cartridges complete with 900ml cartridge and G1/4 adapter

#### Spare parts

Part number	Description
5320-00000018	Cartridge, complete with piston and rivets, 400 ml
532-33916-1	Cartridge, complete with piston and rivets, 900 ml
542-60528-1	Adapter kit with M14x1,5 adapter and O-ring
542-60706-1	Adapter kit with M16x1,5 adapter and O-ring
5420-00000011	Adapter kit with G1/4 adapter and O-ring

[skf.com](https://skf.com) | [skf.com/lubrication](https://skf.com/lubrication)

© SKF and Lincoln are registered trademarks of the SKF Group.

© SKF Group 2024  
The contents of this publication are the copyright of the publisher and may not be reproduced (even extracts) unless prior written permission is granted. Every care has been taken to ensure the accuracy of the information contained in this publication but no liability can be accepted for any loss or damage whether direct, indirect or consequential arising out of the use of the information contained herein.

PUB LS/P2 19149 EN · January 2024

Certain image(s) used under license from Shutterstock.com.